

FULL SURFACE
SWING CLEAR
TEMPLATE HINGES

Template No. T 380
Rev. '96

SIZE: 5

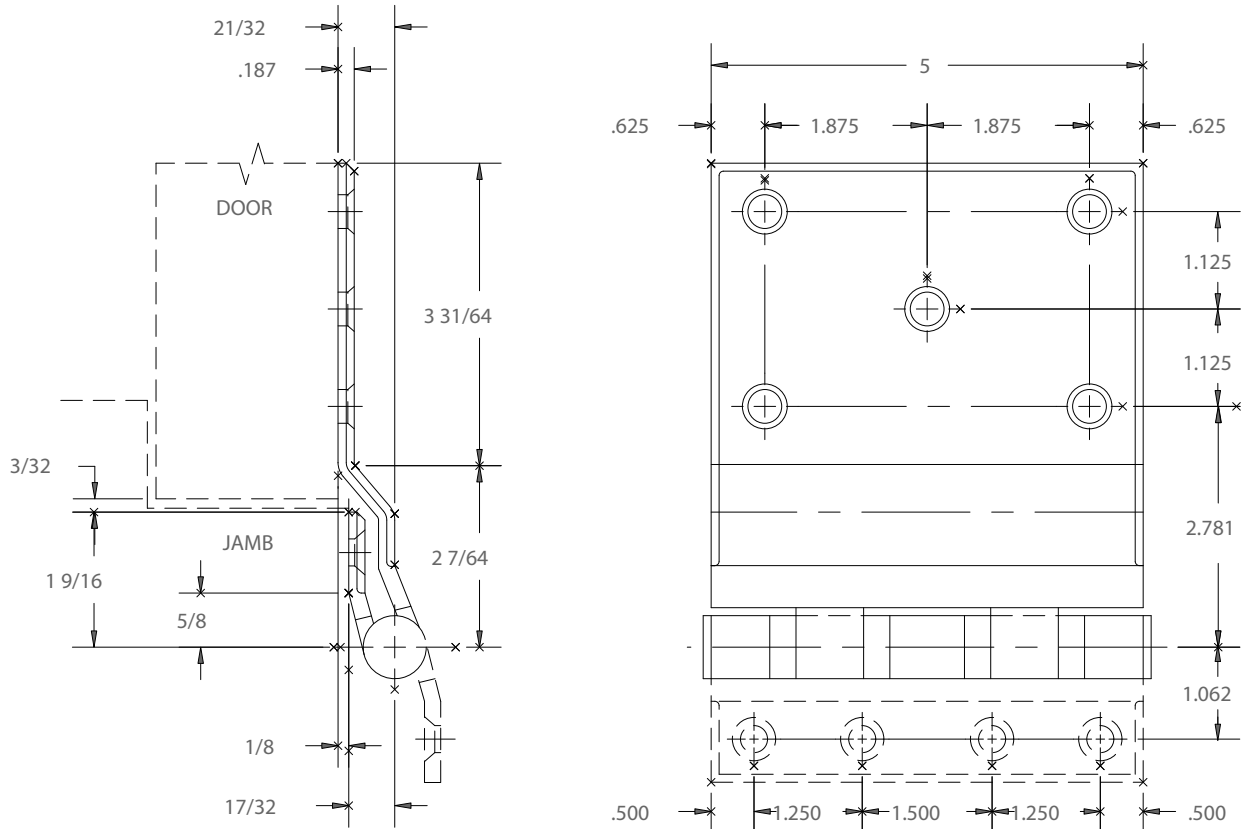

-DO NOT SCALE-

CATALOG NUMBER	
STEEL HINGES	METAL GAUGE
BB1266	.187
BB7523	.187

ALL DIMENSIONS ARE IN INCHES.

Machine Screw Size: Door Leaf- 1/4-20 x 2" O.H. WITH GROMMET NUTS.
 Jamb Leaf- 1/4-20 x 1/2" F.H.

NOTE: This hinge alters the normal pivot point of door. For door closers, friction or overhead door holders to be used in conjunction with this hinge, consult manufacturer of the device for application details.



hospital type template hinges conform to the above screw size and location. they are designated by "HT" to catalog number.

HAGER RESERVES THE RIGHT TO MAKE DESIGN CHANGES WITHOUT NOTICE. CALL HAGER ENGINEERING AT 1-800-325-9995 FOR LATEST REVISION DATE OF TEMPLATE.

HAGER COMPANIES
 139 VICTOR STREET
 P.O. BOX 12300
 ST. LOUIS, MISSOURI 63157-0300

Template No. T 380